

# **Power Smoker** *with LiquiSmoke®*

## Reference Manual and User's Guide



**HURCO**  
TECHNOLOGIES, INC.®

Hurco Technologies, Inc.  
409 Enterprise Street  
Harrisburg, SD 57032  
1-605-743-2466  
[www.gethurco.com](http://www.gethurco.com)

REV 01-15-09-1  
Part PSOM

## Contents

Reference Manual and User's Guide cover page.....	1
Welcome .....	3
General Safety Information .....	4
Power Smoker Setup for Sewer Systems .....	5-9
Public Awareness .....	5
Preparing for Smoke Testing .....	6
Before you start your test .....	7
Procedures for Smoke Testing .....	8
Identifying leaks and recording data .....	9
Power Smoker Parts Breakdown .....	10
Super Power Smoker Parts Breakdown .....	11
Installing Power Smoker Impeller .....	12
Trouble Shooting .....	13
Power Smoker Specifications.....	14

## Welcome

Thank you for purchasing Hurco's Power Smoker. The Power Smoker has been part of Hurco's product line since the mid 1980's. The Power Smoker, formerly Ripcord Smoker, was invented as another use for the Ripcord Ventilator / Stringer. The Power Smoker has proven to be the best way to test aging sewer systems for leaks. With a patented smoke generating system, the Power Smoker is the most economical smoker in the market today. Most importantly, the Power Smoker utilizes our laboratory tested safe LiquiSmoke.

Power Smoker with LiquiSmoke will:

- Provide up to 3 or more hours of smoke! No other manufacturer even comes close.
- Powerful enough to push smoke through the smallest leaks.
- LiquiSmoke will not leave stains or odors.
- Solid Cast Aluminum impeller for maximum performance. Tested in accordance with AMCA (Air Movement and Control Association) standards.

**Hurco Technologies, Inc.** would like to take this opportunity to welcome you as a new customer and user of the Power Smoker with LiquiSmoke. You have just purchased the best smoke testing system available. The Power Smoker is simple to use and will provide you with years of service.

This manual will take you through the step by step procedures for using the Power Smoker. We use simple to understand instructions and photos to assist you in learning how to get the best results from your Power Smoker. Please follow each step completely to insure maximum performance from your Power Smoker.

Your Power Smoker will give you many years of service if you take care of it as you would any expensive piece of equipment. The Power Smoker is rugged and built to last. It will withstand the demands of your jobsite; however, is not abuse proof! Be sure to assign the use of your Power Smoker to a competent worker who will take care of it.

In this manual, we will be giving you suggestions on basic smoke testing activities. As a general rule, these suggestions are based on standard procedures used by cities and contractors throughout the United States and other countries. It should not be necessary to enter a manhole when smoke testing, however, if it becomes necessary, it will be your responsibility to read and understand the OSHA 1910.146 regulation and to always use safe manhole entry procedures. Hurco Technologies, Inc. will not be responsible for the incorrect use of the Power Smoker or for the failure to follow safe manhole procedures. Assign a competent worker with knowledge on proper confined space procedures. You can find a copy of the OSHA regulations on the OSHA website at <http://www.osha.gov> or do a Google search on "OSHA 1910.146". To watch a video on safe confined space ventilation, go to Hurco's website at [www.gethurco.com](http://www.gethurco.com).

**WARNING:** The Power Smoker is not explosion proof. Do not start the Power Smoker in the presence of volatile gases.

If you have any questions regarding this manual or smoke testing in general, please call and ask for customer support at 1-800-888-1436.

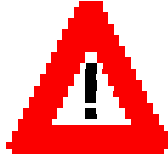

## **WARNING!**

READ ALL OPERATING MANUALS  
BEFORE OPERATION OF EQUIPMENT

## **GENERAL SAFETY INFORMATION**

### **Machine Operation**

- Always wear protective clothing and safety glasses when operating machinery.
- Never service or repair Power Smoker while running. Allow engine to cool.
- Whenever fueling the Power Smoker, shut off engine and do not smoke.
- Periodically inspect system components. Perform routine maintenance as required.
- Do not operate a gasoline engine in an enclosed area. Be sure the area is well ventilated.

### **SAFETY FIRST!**

Even though you are using laboratory tested safe LiquiSmoke, gases from the sewer line may not be safe. Some of these gases can be very dangerous causing anything from minor health symptoms to death. The smoke is a visual indicator that you should evacuate the area immediately. If smoke is detected in a building, follow these procedures;

- If possible, open all doors and windows and evacuate immediately.
- Install a fan in a window or door to evacuate the smoke.
- Find a licensed plumber to fix the leak.
- Once the repair has been made, recheck the system using Hurco's Power Smoker 2.

You should not have to enter a manhole when smoke testing. However, if you find it necessary to enter the manhole to insert a plug or set up a by-pass, you must follow all proper confined space entry techniques. Refer to OSHA's 1910.146 confined space regulation.

For more information concerning confined space entry, go to the Center for Disease Control / NIOSH at <http://www.cdc.gov/NIOSH/> then type "confined space" in the search box.

# Power Smoker Setup for Sewer Systems

---

Setting up your Power Smoker for smoke testing a sewer system involves some planning. The most important part of any smoke testing program is PUBLIC AWARENESS. This should never be taken for granted. There will certainly be people with health concerns and businesses that cannot have business interrupted. Because it is natural to panic whenever you see smoke, notification and awareness will help alleviate that anxiety. Another major concern is the possible presence of dangerous sewer gases traveling with the smoke. When smoke testing, it should not be necessary to enter a manhole. However, before you ever enter a confined space, such as a manhole, you must follow safe confined space entry techniques. Refer to OSHA's 1910.146 regulation and never enter a manhole until it has been thoroughly tested using high quality, calibrated gas detection equipment. Always keep a gas monitor with you at all times. The environment in a manhole can change rapidly.

## Public Awareness

Public Service Announcements, (PSA), are the best way to notify citizens of your intentions. These PSA's can be delivered in a number of different ways:

- Television and Radio Announcements
- Newspapers
- Direct Mail
- Door Hangers

Many television stations, radio stations and newspapers will carry these advertisements for a small fee and sometimes for no fee at all.

All Public Service Announcements need to be timed so that the home or business owner does not forget the day you will be performing this activity. A good practice would be to send a letter to each home and business owner at least two weeks in advance of your smoke testing activities. That should then be followed by the Newspaper, Radio and Television announcements each day during the week prior to the test. You can also visit the neighborhood and put door hangers on each home or business. When using door hangers, be sure to put one on every door. You never know what door is used by the occupant.

Hurco has created some of these PSA materials that are free to use providing you are using our equipment and our LiquiSmoke. These materials are very specific to our products and you can create confusion for your citizens when not using Hurco products. Go to the Hurco website at [www.gethurco.com](http://www.gethurco.com) to download any of these announcements:

- Television Commercial
- Radio Commercial
- Newspaper advertisement
- Direct mail form letter
- Door hanger

Hurco has also created a website directed at the citizens of your community. That website is [www.smoketesting.com](http://www.smoketesting.com). This website will answer frequently asked questions and give each business and homeowner a list of things they can do to prepare for the smoke test. You are welcome to use this website or to link it to your website. Hurco also has a video on smoke testing that can be viewed or downloaded at our website at [www.gethurco.com](http://www.gethurco.com).

# Preparing for Smoke Testing

## **PREPARING MAPS**

It is important to plan your smoke testing activities carefully. You will want to prepare maps of the area to be tested. These maps should identify:

- The direction of sewer flow
- The size of the sewer mains
- The manholes to be used for setting up the Power Smoker
- Intersections or busy roadways to avoid
- Traffic control when necessary
- Home or business owners with special concerns
- Residents with health concerns
- Any other items of concern can also be noted

## **SETTING UP THE CREW**

Two people are all that is required for a smoke testing program. These people should be trained in the proper procedures of smoke testing and dealing with confined spaces. There is no room for errors when doing smoke testing.

## **REQUIRED EQUIPMENT**

- Power Smoker with LiquiSmoke
- Extra gas for Power Smoker
- One service vehicle
- Safety vests and hard hats
- Traffic cones
- Cell phone for emergencies
- Video or digital camera gear
- 100 foot tape measure
- Optional GPS gear
- Note pad with pen or pencil
- Maps with notes
- Marker flags

## Before you start your test

1. Read all warnings on the Power Smoker before operation.
2. Check oil and gas before starting the Power Smoker.
3. Remove Manhole covers on section to smoke test and plug pipes and bypass, if necessary, to isolate the section being tested. It should not be necessary to plug pipes unless the smoke going beyond the test area is of concern.
4. Replace all manhole covers except the manhole where the Power Smoker will be located.
5. Place Power Smoker on manhole.
6. Prepare the LiquiSmoke Tank.
  - a. To relieve pressure from tank before filling, pull up with the small ring on the pressure relief valve located on the top of the tank. **Never open canister without first releasing pressure.**
  - b. Put one gallon of LiquiSmoke in the LiquiSmoke pressure tank
  - c. Place pump back into tank and turn clockwise until tight.
  - d. Disengage the pump handle by turning it ¼ turn and pump tank until firm. Do not apply too much pressure to the pump handle as it will damage the pump cartridge. Note: Putting more than one gallon in this container will cause you to make several trips back to the Power Smoker to keep the LiquiSmoke under pressure. By leaving the tank half full, you will have an adequate amount of pressure to last the entire test. **Warning:** The LiquiSmoke pressure tank is now under pressure and **DANGEROUS**. Always wear eye protection when using this container.

**WARNING!** Smoke testing can be dangerous. Do not use in areas where there are volatile gases. Do not allow a person in any manholes while the smoke test is being conducted.

**WARNING!** Using any liquid product to produce smoke other than Hurco's LiquiSmoke can cause damage to the Power Smoker, voiding any warranty. Also, some of these liquids can start on fire and become an explosion hazard.

**WARNING!** Power Smoker is not designed to be use with zinc chloride smoke bombs. Not only are these smoke bombs corrosive to the working components of the Power Smoker, they can cause serious damage to the engine.

**WARNING!** NIOSH (National Institute for Occupational Safety and Health) says: If *zinc chloride* smoke generating devices are used to generate dense clouds, the smoke should be considered hazardous and participants who enter the smoke should wear a self-contained breathing apparatus (SCBA). Practices like "buddy breathing" should not be conducted in these dense smoke clouds. If individuals experience any breathing difficulties, they should receive medical evaluation as soon as possible. Hurco does not allow the use of zinc chloride smoke bombs with any Power Smoker product.

## Procedures for Smoke Testing

1. The day before the test, notify Police and Fire Department personnel of your activities. There will be no doubt that someone will see your smoke and call for help.
2. Go to each house or business to be tested and leave a door hanger or letter of your activities for the next day.
3. On the day of the test, call Police and Fire Department personnel as a reminder.
4. Identify a two block section to be tested.
5. Go to each house or business where there are health concerns. These people should know to evacuate immediately when seeing smoke or stay out of the building during the test. You can do an inspection for these people before they return to their home or business.
6. Set the Power Smoker on the manhole, connect the LiquiSmoke tank and start the engine.
7. Let the engine warm for a few minutes then slowly open the LiquiSmoke valve about 1/16 to 1/4 turn. This can vary and should be determined prior to doing your project.
8. Watch for smoke coming from vents on top of buildings before starting your inspection.

Note: Power Smoker will produce approximately 3 hours of smoke from one gallon of LiquiSmoke. It should take you about 20 minutes to inspect a 2 block area or about 800 feet. Each gallon of LiquiSmoke should produce enough smoke to test about 7,200 feet of pipe. The condition and size of the pipe and the number of sewer laterals will have an effect on the exact number of feet that can be tested with one gallon of LiquiSmoke.



Typical set up for Smoke Testing

## Follow these steps when inspecting for sewer leaks:

1. Worker #1 will walk down one side of the street, moving one block and looking carefully around each house or business. Worker #1 will then cross the street, moving two blocks in the opposite direction and continue looking around each house and business. At the end of that two block section, Worker #1 will cross the street, moving one block back towards the Power Smoker.
2. Worker # 2 will repeat this procedure moving in the opposite direction. This method of inspection will give Worker # 1 and 2 the opportunity to identify leaks that the other may have missed. Sometimes it takes a long time before smoke exits the ground and this will assure no leaks are missed.

## Double check procedure



Worker #1   
Worker #2 

## Identifying leaks and recording data

While you are doing your inspection, you should be aware that sewer lines can run anywhere so a thorough inspection around buildings is necessary. Sometimes these leaks will emit very small amounts of smoke, barely visible without careful inspection. Look under bushes, next to building foundations and even peer into windows to see if smoke is getting into the building. There could be a plumbing problem in the building that is causing the smoke to enter or the building owner may have illegally connected a sump pump to the plumbing system. Look at drain spouts on building to see if there is an illegal connection. When you identify a leak, take these steps:

1. Mark the leak with a flag.
2. Videotape or take a digital picture of the leak. It is a good idea to take a picture of the building with a focus on the address. These pictures will give you some idea of how bad the leak is and where it is when you prepare your final report.
3. Take a measurement from a stationary object that will not be moved anytime soon. It is best to take 2 or 3 measurements to triangulate the leak. Mark these measurements on your map. Note: You may want to come back after your smoke test to take these measurements in order to save time, but you should get the pictures while the smoke is coming out.
4. As an option, you may take a GPS reading on the leak.
5. Take notes while the test is fresh in your mind. Do not wait until you get back to the office.

# Power Smoker Parts Breakdown

This parts breakdown is to help you identify any parts that may need to be replaced or repaired. You should never remove or install the cast aluminum impeller without following the instructions found on page 12 of this manual. For help repairing your Power Smoker or ordering parts, call our office at 1-800-888-1436.

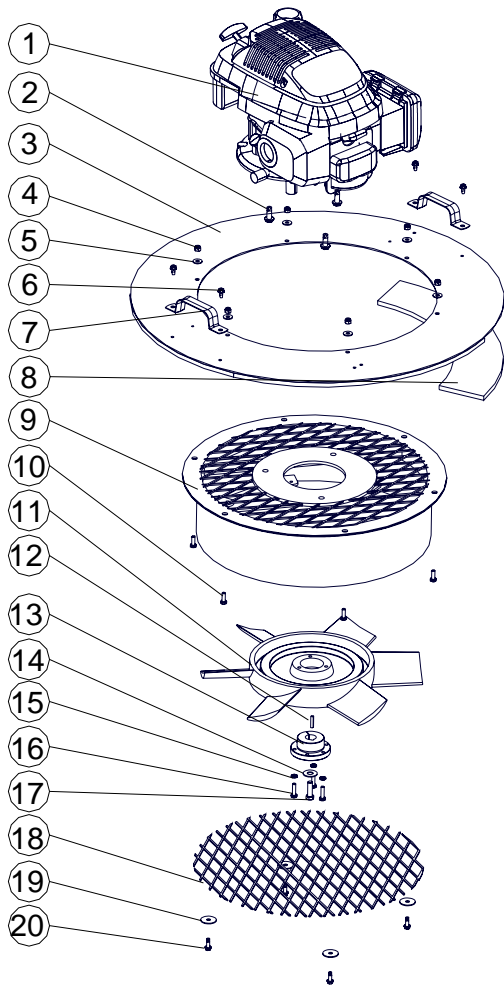

REF NO.	PART DESCRIPTION	NO. REQD.	PART NO.
1A	BRIGGS & STRATTON ENGINE (5.5 HP)	1	4300-101
1B	HONDA ENGINE (5.5 HP)	1	4300-102
2	ENGINE BOLT	3	903-101
3	FLANGE	1	4300-108
4	1/4-20 NYLOCK HEX NUT	6	901-001
5	1/4 FLATWASHER	6	901-201
6	1/4-20 X 1/2" TS HCS	4	901-201
7	HANDLE	2	909
8	RUBBER SEAL	4	4300-111
9	RIP18 BASE FRAME	1	4300-103
10	1/4-20 X 3/4" HCS	6	901-102
11	18" RIPCORDER IMPELLER	1	PRP18
12A	KEYSTOCK (BRIGGS & STRATTON)	1	4300-105
12B	WOODRUFF KEY (HONDA)	1	4300-110
13	BROWNING TAPERLOCK BUSHING 7/8"	1	4300-104
14	7/16 FLATWASHER	1	904-020
15	5/16" LOCKWASHER	3	902-030
16	5/16-18 X 1 HCS	3	902-103
17	3/8-16 x 1.5 HCS	1	903-104
18	BOTTOM PROTECTION SCREEN	1	4300-107
19	1/4" FENDERWASHER	4	901-024
20	1/4-20 X 3/4" TCS	4	901-202

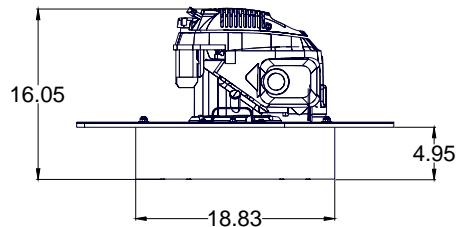
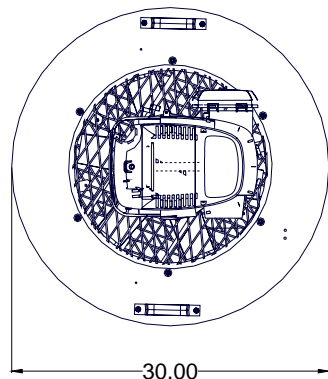

80 LBS. DRY WEIGHT

# Super Power Smoker Parts Breakdown

This parts breakdown is to help you identify any parts that may need to be replaced or repaired. You should never remove or install the cast aluminum impeller without following the instructions found on page 12 of this manual. For help repairing your Ripcord or ordering parts, call our office at 1-800-888-1436.

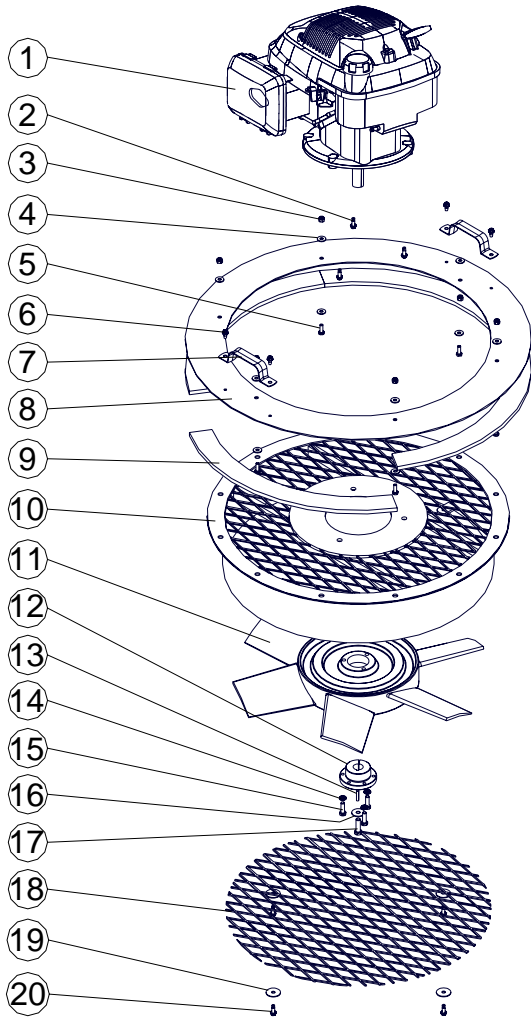

REF		NO.	PART
NO.	PART DESCRIPTION	REQD.	NO.
1A	BRIGGS & STRATTON ENGINE (5.5 HP)	1	4300-101
1B	HONDA ENGINE (5.5 HP)	1	4300-102
2	ENGINE BOLT	3	903-101
3	1/4-20 NYLOCK HEX NUT	6	901-001
4	1/4 FLATWASHER	6	901-201
5	1/4-20 X 3/4" HCS	6	901-102
6	1/4-20 X 1/2" TS HCS	4	901-201
7	HANDLE	2	909
8	RIP24 FLANGE	1	4300-207
9	RUBBER SEAL	4	4300-111
10	RIP18 BASE FRAME	1	4300-202
11	24" RIPCORD IMPELLER	1	PRP24
12	BROWNING TAPERLOCK BUSHING 7/8"	1	4300-104
13A	KEYSTOCK (BRIGGS & STRATTON)	1	4300-105
13B	WOODRUFF KEY (HONDA)	1	4300-110
14	5/16" LOCKWASHER	3	902-030
15	5/16-18 X 1 HCS	3	902-103
16	7/16 FLATWASHER	1	904-020
17	7/16-14 x 1.5 HCS	1	904-104
18	24" BOTTOM PROTECTION SCREEN	1	4300-226
19	1/4" FENDERWASHER	4	901-024
20	1/4-20 X 3/4" TCS	4	901-202

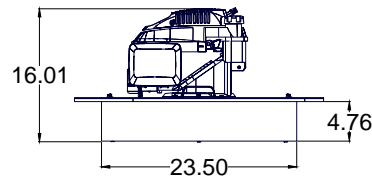
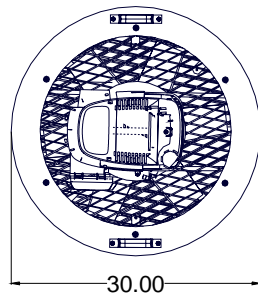

# LiquiSmoke System Parts Breakdown

This parts breakdown is to help you identify any parts that may need to be replaced or repaired.

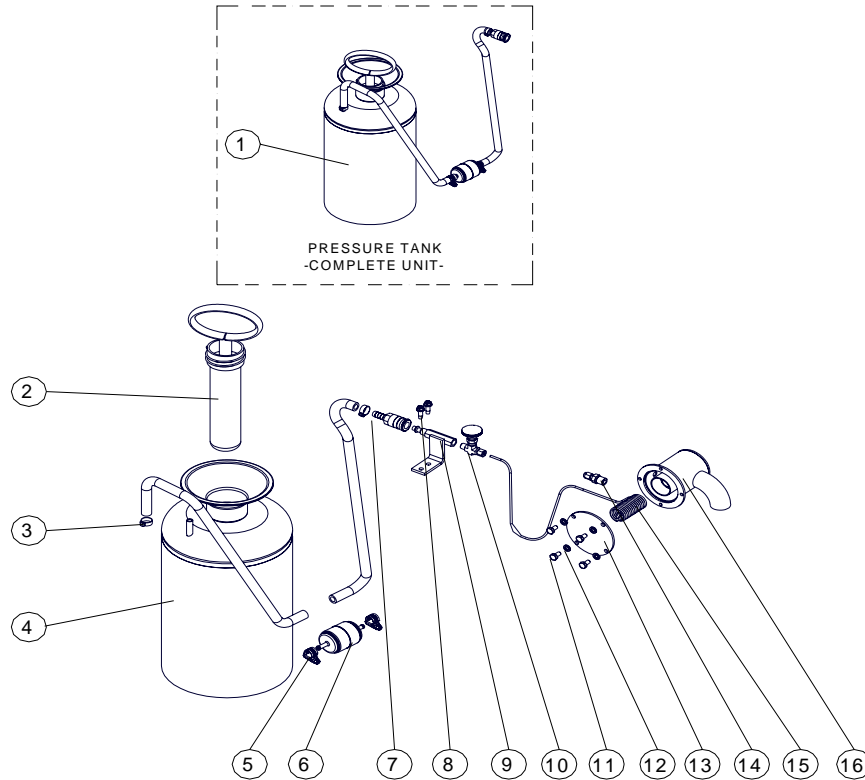

REF NO.	NO.	PART DESCRIPTION	PART NO.
1	1	RIPCORD LIQUISMOKE PRESSURE TANK (COMPLETE)	4300-300A
2	1	TANK PLUNGER	4300-300-13
3	2	SMOKER CRIMP CLAMP	4300-330
4	1	TANK	4300-301
5	2	1/4" HOSE CLAMP	990-410
6	1	IN-LINE FILTER	4300-335
7	1	FEMALE QUICK COUPLER	4300-304
8	2	SELF TAPPING HEX SCREWS 1/2" X 1/2"	901-201
9	1	"L" BRACKET	4300-313
10	1	NEEDLE VALVE	4300-829
11	4	CAPSCREW 1/2" X 1/2" NC	901-101
12	4	LOCK WASHER 1/4"	901-030
13	1	MUFFLER COVER	4300-842
14	1	COUPLER 1/8" X 1/4"	4300-827
15	1	REPLACEMENT COIL (WITH FITTINGS)	4300-826A
16A	1	BRIGGS LIQUISMOKE MUFFLER (inc. cover)	4300-306
16B	1	HONDA LIQUISMOKE MUFFLER (inc. cover)	4300-308

# Installing Power Smoker Impeller

---

Installing the impeller on your Power Smoker is not difficult but must be done as outlined below. A cracked impeller is not covered under our warranty, so it is important to follow each step carefully. For help repairing your Power Smoker or ordering parts, call our office at 1-800-888-1436.

## ***Follow these steps to remove an impeller:***

1. Drain all gas and oil from the Power Smoker.
2. Turn Power Smoker upside down and remove the expanded metal guard.
3. Remove the center bolt from the impeller.
4. Remove the three securing bolts from the taper lock bushing.
5. Reinstall two of the bolts into the threaded holes in the taper lock bushing.
6. Slowly and evenly tighten bolts until taper lock bushing separates from the impeller.
7. Remove Impeller and taper lock bushing.

**Note:** The Power Smoker impeller was installed using Loc-Tite 609 adhesive. It may be necessary to warm the taper lock bushing to help release this adhesive. Do not apply too much heat.

## ***Follow these steps to install an impeller:***

1. Make sure engine shaft is clean and the bore on the taper lock bushing is clean. Using a quality brake parts cleaner will make this much easier. Remove any burrs or nicks from all metal parts.
2. Align holes of taper lock bushing with the threaded holes in the impeller. The taper lock bushing is tapered and must align into the impeller so the taper in the impeller matches the taper of the taper lock bushing.
3. Be sure to align the keyway on the motor shaft with the black line on the impeller. This black line is a balance mark and it is critical to have it in line with the keyway to prevent vibration.
4. Use Loc-Tite 609 on engine shaft, the inside and outside of the taper lock bushing and on all bolts. Loc-Tite 609 is the only acceptable adhesive. Using another adhesive may cause a failure of the impeller.
5. When the impeller and bushing are properly placed on the engine shaft, the shaft should be approximately 1/8" to 1/4" inside the bushing. You can use a thick piece of cardboard as a gauge on the distance to hold the impeller away from the engine mounting support brackets.
6. Gradually and evenly tighten the three taper lock bushing bolts by turning 1/4 turn at a time and rotating to the next bolt. Note: The taper lock bushing must be installed evenly or it could damage the impeller. DO NOT USE AN IMPACT WRENCH! All tightening must be done by hand. Special bolts were shipped with your impeller. Do not attempt to use bolts other than those supplied because they could cause damage to the impeller. Damage caused during installation is not covered under warranty.
7. Do not use torque instructions on the box provided with the taper lock bushing. These instructions are for installing a cast iron pulley on an engine shaft. This is too much torque for the Power Smoker impeller. Recommended torque for the taper lock bushing when used with the Power Smoker impeller is 10 ft. lbs of torque. This is a situation where tighter is not better. Over tightening of the taper lock bushing will break the impeller which is not covered under warranty.
8. **CAUTION:** Do not attempt to tighten the collar of the taper lock bushing tight against the impeller. This will break the impeller which is not covered under warranty. There should be about 1/8" to 1/4" space between the collar of the taper lock bushing and the impeller when installed correctly.
9. Install center washers into the taper lock bushing to fill gap from end of engine shaft to the face of the taper lock bushing. Install center bolt. Remember, you must use the Loc-Tite 609 adhesive on all contact surfaces and on all bolts.
10. Install protective expanded metal screen.
11. Let Ripcord sit for 24 hours before using to allow the Loc-Tite 609 to cure.
12. Put oil and gas in engine.

# Trouble Shooting

---

**Question:** Why is my Power Smoker spitting out too much LiquiSmoke?

**Answer:** The valve on the Power Smoker that controls the flow of the LiquiSmoke is open too far. This will allow too much fluid to enter the Smoke Generator causing it to cool and not properly atomize the LiquiSmoke. It is advisable to practice with the Power Smoker to determine the exact position of the flow control valve to produce the maximum smoke with little wasted LiquiSmoke prior to use on a job. A small amount of fluid emitting with the smoke is normal.

**Question:** Why isn't my Power Smoker producing dense smoke?

**Answer:** The LiquiSmoke flow control valve is open too far causing the smoke generator to cool. Close valve and allow excess LiquiSmoke to burn off. Now open the valve slowly until you reach maximum smoke generation. This will only take a fraction of a turn on the LiquiSmoke flow control valve.

# Power Smoker Specifications

---

## **CFM Rating**

The Hurco Power Smoker impellers were tested in accordance with AMCA ( Air Movement and Control Association) standards.

Power Smoker – 6211 CFM @ 0.001 static pressure (**free air**)  
Super Power Smoker – 12,987 CFM @ 0.001 static pressure (**free air**)

Power Smoker – 5632 CFM @ 1.000 static pressure  
Super Power Smoker – 12,101 CFM @ 1.000 static pressure

Power Smoker – 4130 CFM @ 3.000 static pressure  
Super Power Smoker – 8761 CFM @ 3.000 static pressure

## **Engine options**

Briggs & Stratton 5.5 HP  
Honda 5.5 HP

**Note: Refer to engine manufactures manual for warranty information and maintenance instructions.**

## **LiquiSmoke**

Approximately 3 hours of smoke delivery out of one gallon of LiquiSmoke.

### **Limited Warranty**

When used in accordance with instructions, HURCO Technologies, Inc. will replace to the original purchasers, free of charge, any part or parts of the Ripcord unit, excluding the engine, found to be defective in material or workmanship or both; this is the exclusive remedy. All transportation charges on parts submitted for replacement under this Warranty must be borne by the purchaser. The engine is warranted as outlined by the engine manufacturer's separate, limited warranty only. This warranty does not cover damage or loss to the Ripcord unit from operating negligence, or due to accident or other casualty. **THERE IS NO OTHER EXPRESS WARRANTY OR IMPLIED WARRANTIES. THIS WARRANTY IS LIMITED TO A PERIOD OF ONE YEAR FROM THE DATE OF PURCHASE AND TO THE EXTENT PERMITTED BY APPLICABLE LAW, ANY AND ALL IMPLIED WARRANTIES, INCLUDING THOSE OF MERCHANTABILITY AND FITNESS FOR A PARTICULAR PURPOSE, ARE HEREBY EXCLUDED, TO THE EXTENT PERMITTED BY LAW. IN NO EVENT SHALL WARRANTOR BE LIABLE FOR DIRECT, INDIRECT, INCIDENTAL AND CONSEQUENTIAL DAMAGES RESULTING FROM ANY DEFECT IN THE GOODS, TO THE EXTENT SUCH AVOIDANCE IS PERMITTED BY APPLICABLE LAW.**