

Power Smoker II

FOR LEAK ANALYSIS OF PLUMBING SYSTEMS

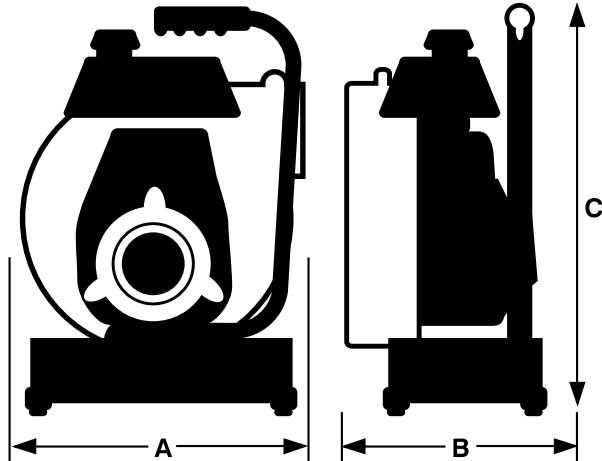

Special Features:

- 2.5 HP Honda GXH50 4 Stroke engine.
- Enclosed fan system capable of up to 700 cfm with adjustable inlet damper control to adjust cfm as necessary for the size of system.
- Utilizes LiquiSmoke™, a tested non-toxic, non-staining smoke fluid. LiquiSmoke™ pressure tank with in-line filter and quick disconnect. LiquiSmoke™ flow controlled by precision needle valve.
- 4" x 6' industrial flexible mining duct to connect to vent stack or clean out.
- High performance **SuperJet™** muffler. Continuous and constant smoke production. Nearly 100% burn - little to no wasted LiquiSmoke™ making it the most cost-effective smoke in the industry. See it work at our website.

Physical Specifications (See illustration above)

Dimension	PowerSmoker II
A	14.5"
B	15"
C	20"
Weight	47 LBS.
Gas Tank Capacity	.32 gals

High pressure cast aluminum fan - up to 700 CFM at 8.0 Static Pressure.

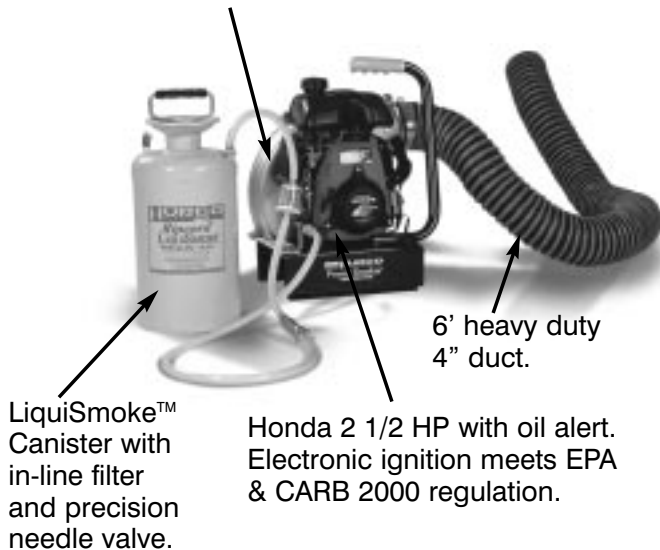

HURCO
TECHNOLOGIES, INC.

P.O. Box 70 • Harrisburg, SD 57032

1-800-888-1436

Toll Free Fax #: 1-800-516-7337

www.hurcotech.com